

Left Side Compartmentation				
Compt	Doors	Opening Dimensions	Inside Dimensions WxHxD	Volume
L1	Roll Up	36x56	43x66x27.25	44.8 CU FT
L2	Roll Up	57x22	64x32x27.25	32.3 CU FT
L3	Roll Up	46x56	53x66x27.25	55.2 CU FT
Right Side Compartmentation				
Compt	Doors	Opening Dimensions	Inside Dimensions WxHxD	Volume
R1	Roll Up	36x56	43x66x27.25	44.8 CU FT
R2	Roll Up	57x22	64x32x27.25	32.3 CU FT
R3	Roll Up	46x56	53x66x27.25	55.2 CU FT
Rear Compartmentation				
Compt	Doors	Opening Dimensions	Inside Dimensions WxHxD	Volume
A1	Roll Up	35x18	42x28x29	19.7 CU FT
Total Volume				284.2 CU FT

Hale Qmax 2000 single stage  
Water Tank Capacity 1000 gal

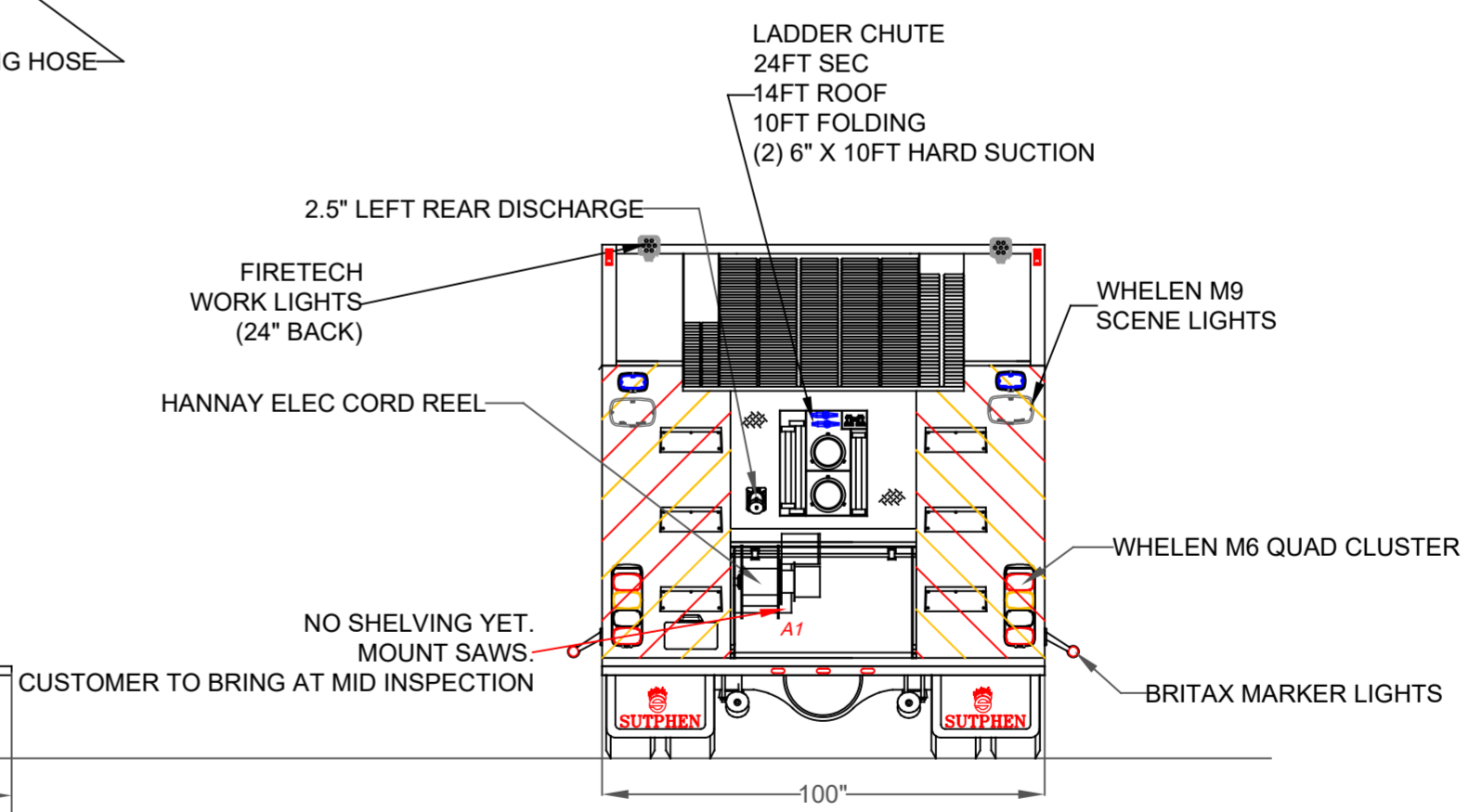
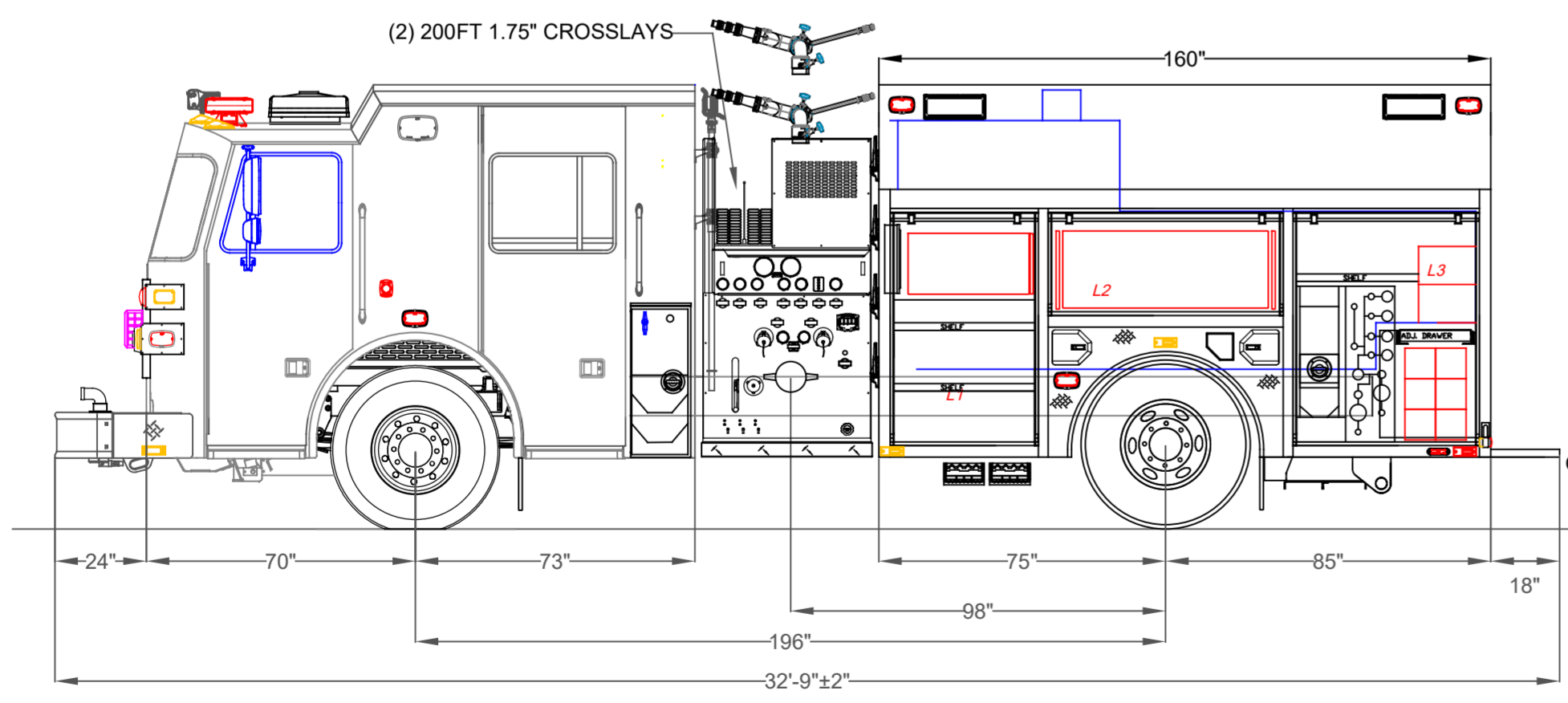

DIMENSIONS SHOWN ON THIS DRAWING ARE APPROXIMATE AND ARE SUBJECT TO MINOR DEVIATIONS DURING CONSTRUCTION.

IN THE EVENT OF A DISCREPANCY BETWEEN THE SUTPHEN SPECIFICATIONS AND DRAWING, THE SUTPHEN SPECIFICATIONS SHALL PREVAIL.

DRAWING IS FOR REFERENCE ONLY. SOME ITEMS PROPOSED MAY NOT BE SHOWN OR NOTED.

**CUSTOMER APPROVAL**

NAME: \_\_\_\_\_

TITLE: \_\_\_\_\_

DATE: \_\_\_\_\_

REV.	DESCRIPTION	BY	DATE
C	CHANGE GRILLE TO AMERICAN FLAG LASER CUT	SED	8/24/20
B	CHANGES FROM PRE-CON	SED	5/28/20
A	CHANGES FROM PRE-CON	SED	5/26/20

THIS PRINT IS PROVIDED ON A RESTRICTED BASIS AND IS NOT TO BE USED IN ANY WAY DETRIMENTAL TO THE INTEREST OF SUTPHEN CORPORATION.

DRAWN BY: S.DORFMAN

DATE: 02/12/2020

MFG. FACILITY: SUTPHEN EAST LAKE ARIEL, PA

DWG. NO.: HS 6805

SUTPHEN EAST  
55 INNOVATION DRIVE  
LAKE ARIEL, PA  
1-844-776-2889

STOCKPORT FIRE DISTRICT  
HUDSON, NY

CUSTOM PROGRAM 2 ALUMINUM PUMPER